

# MCJQ series

## COMPACT CYLINDERS

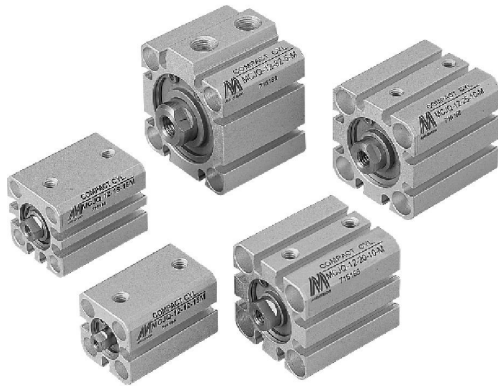

### Features

- Ultra Compact, light weight and space saving cylinder.
- Wide range of bore sizes and strokes (12mm~100mm).
- Single and double acting available.
- Ideal for use in machinery where space is limited and incorporating sensor groove which enables flush fitting of sensors.
- Sensor can be mounted on any one of three faces on 12 and 16 bore and on four faces on 20~100 bore.

### Specification

Model	MCJQ				
Acting type	Double acting				
Tube I.D.(mm)	12, 16	20, 25	32, 40	50, 63	80, 100
Port size	M5×0.8		Rc1/8	Rc1/4	Rc3/8
Medium	Air				
Operating pressure range	0.07~1	0.05~1 MPa			
Proof pressure	1.5 MPa				
Ambient temperature	-5°C~+60°C (No freezing)				
Available speed range	50~500 mm/sec				
Sensor switch (※)	RCE, RCE1			RCB, RCE, RCE1	

※ RCB, RCE, RCE1 specification, please refer to page V-07, V-09.

### Double acting-Table for standard stroke

Tube I.D.	Standard stroke	Long stroke (mm)
φ 12,16	5,10,15,20,25,30	35, 40, 45, 50, 75,100
φ 20	5,10,15,20,25,	75,100,125,150,175,200
φ 25	30,35,40,45,50	75,100,125,150,175,200,250,300
φ 32~80	5,10,15,20,25,30,	125,150,175,200,250,300
	35,40,45,50,75,100	

  

Tube I.D.	Standard stroke (mm)
φ 100	5,10,15,20,25,30,35,40,45,50,75,100

- Stroke out of specification is also available.
- Please consult us if stroke out of specification.

### Order example

MCJQ - 12 - 20 - 25M F - G

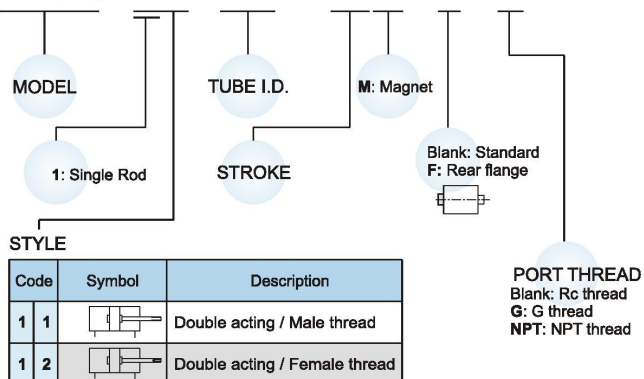

※ Order example for special specification, refer to page J-03.

### Mounting accessories

FAC - MCJQ - 20

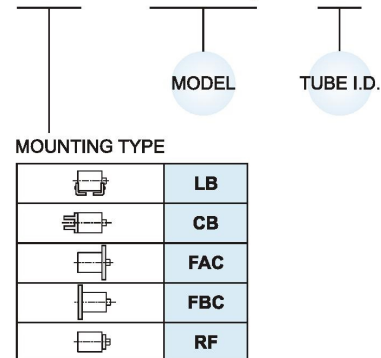

# MCJQ Inside structure & Parts list / Standard stroke

## COMPACT CYLINDERS

Standard stroke

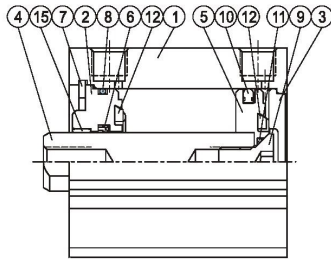

Standard stroke  
(with magnet)

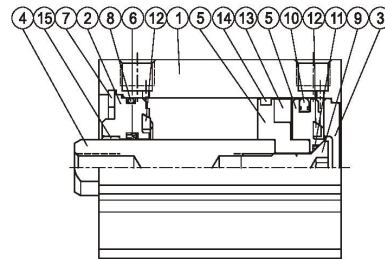

### Standard stroke — Material

No.	Part name	Tube I.D.									Note	Q'y	Component parts (inclusion)	Repair kits (inclusion)	
		12	16	20	25	32	40	50	63	80					100
1	Body	Aluminum alloy									Hard anodized	1			
2	Rod cover	Aluminum alloy									$\phi 12-\phi 32$ hard anodized $\phi 40-\phi 100$ anodized	1	●		
3	End cover	Aluminum alloy									Anodized	1	●		
4	Piston rod	With magnet	Stainless steel			Carbor steel							1		
		Without magnet	SUS	Carbor steel										1	
5	Piston	Aluminum alloy									$\phi 12-32$ anodized	1	●		
6	Rod packing	NBR										1	●	●	
7	Snap ring	Stainless steel			Spring steel							1	●		
8	Cover ring	NBR										1	●	●	
9	Piston bolt	Stainless steel			SCM							1	●		
10	Piston packing	NBR										1	●	●	
11	Piston gasket	NBR										1	●	●	
12	Cushion packing	NBR										2	●	●	
13	Magnet	Plastic										1	●		
14	Wear ring	—			Teflon							1	●		
15	Bush	—			Bearing alloy							1	●		

### Standard stroke — Seal kit

Acting type	Rod packing	Piston packing	Cover ring	Piston gasket
	Double action			
Qty.	1	1	1	1
12	KSYR-6	OPA-12	S-11	d4 × w1
16	KSYR-8	OPA-16	S-14	d5 × w1
20	KSYR-10A	OPA-20	S-18	d6 × w1
25	KSYR-12	OPA-25	S-22.4	d8 × w1
32	KSYR-16	OPA-32	S-28	S-9
40	KSYR-16	OPA-40	S-36	S-10
50	KSYR-20	OPA-50	S-46	S-16
63	KSYR-20	OPA-63	S-60	S-16
80	ORA-25	OPA-80	G-75	d20 × w1
100	ORA-30	OPA-100	G-95	S-26

### Order example

#### Component parts

Tube I.D.	Component parts
$\phi 12$	CP-MCJQ-12-12(M)
$\phi 16$	CP-MCJQ-12-16(M)
$\phi 20$	CP-MCJQ-12-20(M)
$\phi 25$	CP-MCJQ-12-25(M)
$\phi 32$	CP-MCJQ-12-32(M)
$\phi 40$	CP-MCJQ-12-40(M)
$\phi 50$	CP-MCJQ-12-50(M)
$\phi 63$	CP-MCJQ-12-63(M)
$\phi 80$	CP-MCJQ-12-80(M)
$\phi 100$	CP-MCJQ-12-100(M)

#### Repair kits

Tube I.D.	Repair kits
$\phi 12$	PS-MCJQ-12-12
$\phi 16$	PS-MCJQ-12-16
$\phi 20$	PS-MCJQ-12-20
$\phi 25$	PS-MCJQ-12-25
$\phi 32$	PS-MCJQ-12-32
$\phi 40$	PS-MCJQ-12-40
$\phi 50$	PS-MCJQ-12-50
$\phi 63$	PS-MCJQ-12-63
$\phi 80$	PS-MCJQ-12-80
$\phi 100$	PS-MCJQ-12-100

M: With magnet

# MCJQ Inside structure & Parts list / Long stroke

## COMPACT CYLINDERS

Long stroke

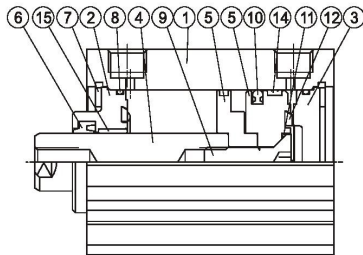

Long stroke  
(with magnet)

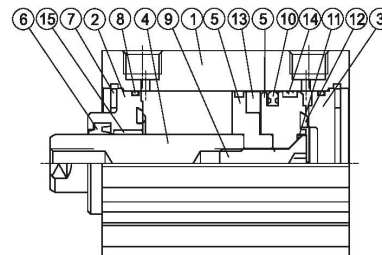

### Long stroke — Material

No.	Part name	Tube I.D.								Note	Q'y	Component parts (inclusion)	Repair kits (inclusion)
		12	16	20	25	32	40	50	63				
1	Body	Aluminum alloy								Hard anodized	1		
2	Rod cover	Aluminum alloy								φ 12-φ 32 hard anodized φ 40-φ 80 anodized	1	●	
3	End cover	Aluminum alloy								Anodized	1	●	
4	Piston rod	With magnet	Stainless steel				Carbor steel					1	
		Without magnet	SUS Carbor steel									1	
5	Piston	Aluminum alloy								φ 12-32 anodized	1	●	
6	Rod packing	NBR									1	●	●
7	Snap ring	Stainless steel				Spring steel					2	●	
8	Cover ring	NBR									2	●	●
9	Piston bolt	Stainless steel				SCM					1	●	
10	Piston packing	NBR									1	●	●
11	Piston gasket	NBR									1	●	●
12	Cushion packing	NBR									2	●	●
13	Magnet	Plastic									1	●	
14	Wear ring	Teflon									1	●	
15	Bush	—				Bearing alloy					1	●	

### Long stroke — Seal kit

	Rod packing	Piston packing	Cover ring	Piston gasket
Acting type	Double action			
Qty.	1	1	2	1
12	KSYR-6	OPA-12	S-11	d4 × w1
16	KSYR-8	OPA-16	S-14	d5 × w1
20	KSYR-10A	OPA-20	S-18	d6 × w1
25	KSYR-12	OPA-25	S-22	d8 × w1
32	KSYR-16	OPA-32	d28 × w2	S-9
40	ORA-16	OPA-40	S-36	S-10
50	ORA-20	OPA-50	S-46	S-16
63	ORA-20	OPA-63	S-60	S-16
80	ORA-25	OPA-80	AS-41	G-75
				d20 × w1

### Order example

#### Component parts

Tube I.D.	Component parts
φ 12	CPL-MCJQ-12-12(M)
φ 16	CPL-MCJQ-12-16(M)
φ 20	CPL-MCJQ-12-20(M)
φ 25	CPL-MCJQ-12-25(M)
φ 32	CPL-MCJQ-12-32(M)
φ 40	CPL-MCJQ-12-40(M)
φ 50	CPL-MCJQ-12-50(M)
φ 63	CPL-MCJQ-12-63(M)
φ 80	CPL-MCJQ-12-80(M)

#### Repair kits

Tube I.D.	Repair kits
φ 12	PSL-MCJQ-12-12
φ 16	PSL-MCJQ-12-16
φ 20	PSL-MCJQ-12-20
φ 25	PSL-MCJQ-12-25
φ 32	PSL-MCJQ-12-32
φ 40	PSL-MCJQ-12-40
φ 50	PSL-MCJQ-12-50
φ 63	PSL-MCJQ-12-63
φ 80	PSL-MCJQ-12-80

M: With magnet

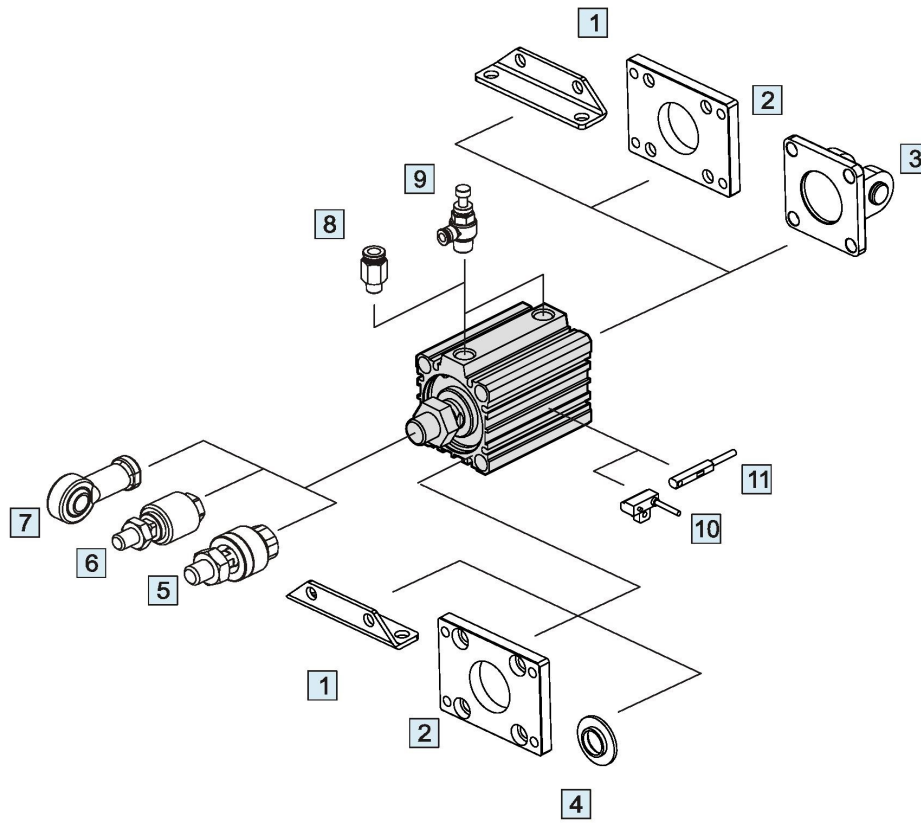

No.	Accessories	Page
1	Mounting accessories LB	K-08,10
2	Mounting accessories FAC/FBC	K-08,09,11,12
3	Mounting accessories CB+PIN	K-09,13,14
4	Mounting accessories RF	K-14
5	Floating joint MFC	V-01
6	Floating joint MFCS	V-03
7	Female rod ends PHS	V-04

No.	Accessories	Page
8	Fitting PC (PISCO)	H-03
9	Speed controller JSC (PISCO)	H-14
10	Sensor switch RCB	V-07
11	Sensor switch RCE/RCE1	V-09

# MCJQ Dimensions $\phi 12 \sim \phi 32$

## COMPACT CYLINDERS

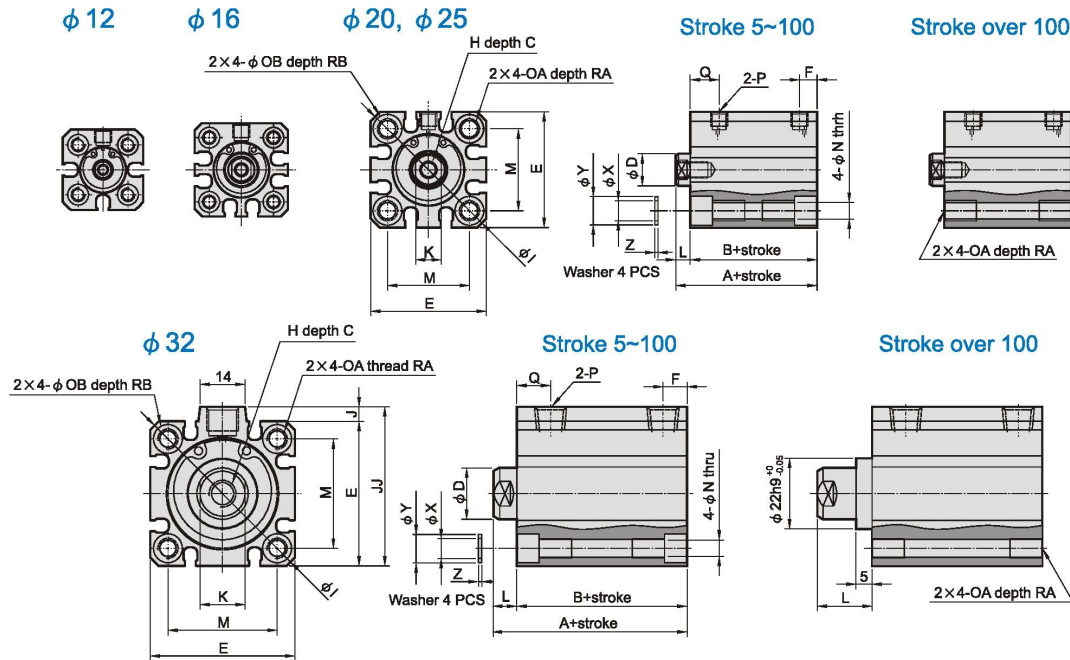

$\phi 12 \sim 25$

$\phi 32$  for Stroke 5~100

$\phi 32$  for Stroke over 100

**MCJQ-11 male thread size**

Code Tube I.D.	C1	H1	L1	L2	X
12	9	M5×0.8	14	24	10.5
16	10	M6×1.0	15.5	25.5	12
20	12	M8×1.25	18.5	28.5	14
25	15	M10×1.25	22.5	32.5	17.5
32	20.5	M14×1.5	28.5	38.5	23.5

※ L1 :Standard stroke, L2 :Long stroke

### $\phi 12 \sim 25$

Code Tube I.D.	Standard stroke								Long stroke																						
	Without magnet				Magnet				Stroke range	A	B	F	L	C	D	E	H	I	K	M	N	OA	OB	P	Q	RA	RB	X	Y	Z	
	A	B	F	L	A	B	F	L																							
12	5~30	20.5	17	5	3.5	25.5	22	5	3.5	31~100	45.5	32	7.5	13.5	6	6	25	M3×0.5	32	5	15.5	3.5	M4×0.7	6.5	M5×0.8	7.5	7	4	4.2	6.3	0.5
16	5~30	20.5	17	5	3.5	25.5	22	5	3.5	31~100	45.5	32	7.5	13.5	8	8	29	M4×0.7	38	6	20	3.5	M4×0.7	6.5	M5×0.8	7.5	7	4	4.2	6.3	0.5
20	5~50	24	19.5	5.5	4.5	34	29.5	5.5	4.5	51~200	55.5	41	9	14.5	7	10	36	M5×0.8	47	8	25.5	5.4	M6×1.0	9	M5×0.8	9	10	7	6.2	8.8	1
25	5~50	27.5	22.5	5.5	5	37.5	32.5	5.5	5	51~300	59	44	11	15	12	12	40	M6×1.0	52	10	28	5.4	M6×1.0	9	M5×0.8	11	10	7	6.2	8.8	1

### $\phi 32$

Code Tube I.D.	Standard stroke						Long stroke																									
	Stroke range	Without magnet		Magnet		Q	Stroke range	A	B	F	L	Q	P	C	D	E	H	I	J	JJ	K	M	N	OA	OB	RA	RB	X	Y	Z		
		A	B	A	B																											
32	5~50	30	23	40	33	7.5	7	10.5	101~300	62.5	45.5	12.5	17	12.5	Rc1/8 (※1)	13	16	45	M8×1.25	60	4.5	49.5	14	34	5.5	M6×1.0	9	10	7	6.2	8.8	1
	51~100	40	33	40	33	7.5	7	10.5																								

※1: Without magnet with stroke=5mm, P=M5×0.8 · Q=11.5 · F=5.5

# MCJQ Dimensions $\phi 40 \sim \phi 100$

## COMPACT CYLINDERS

### $\phi 50 \sim \phi 100$

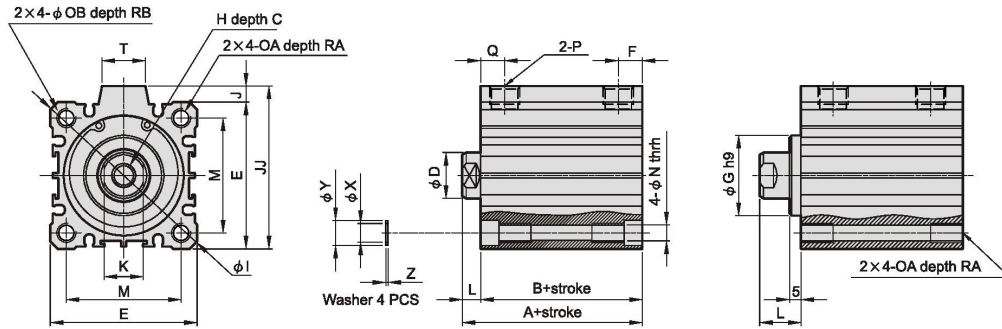

Stroke 5~100

Stroke over 100

### $\phi 40$

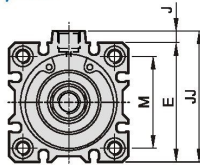

$\phi 40 \sim \phi 100$   
(Stroke 5~100)

$\phi 40 \sim \phi 80$   
(Stroke over 100)

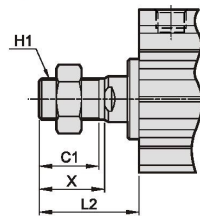
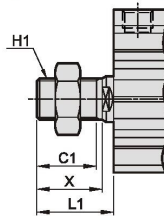

MCJQ-11 male thread size

Code Tube I.D.	C1	H1	L1	L2	X
40	20.5	M14×1.5	28.5	38.5	23.5
50	26	M18×1.5	33.5	43.5	28.5
63	26	M18×1.5	33.5	43.5	28.5
80	32.5	M22×1.5	43.5	53.5	35.5
100	32.5	M26×1.5	43.5	—	35.5

Code Tube I.D.	Standard stroke									Long stroke				
	Stroke range	Without magnet		Magnet		F	L	Q	Stroke range	A	B	F	L	Q
		A	B	A	B									
40	5~50	36.5	29.5	46.5	39.5	8	7	11	125~300	72	55	14	17	14
	75, 100	46.5	39.5											
50	5~50	38.5	30.5	48.5	40.5	10.5	8	10.5	125~300	73.5	55.5	14	18	14
	75, 100	48.5	40.5											
63	5~50	44	36	54	46	10.5	8	15	125~300	75	57	16.5	18	16.5
	75, 100	54	46											
80	5~50	53.5	43.5	63.5	53.5	12.5	10	16	125~300	86	66	19	20	19
	75, 100	63.5	53.5											
100	5~50	65	53	75	63	13	12	23						
	75, 100	75	63											

Code Tube I.D.	C	D	E	G <sup>h9</sup>	H	I	J	JJ	K	M	N	OA	OB	P	RA	RB	T	X	Y	Z
40	13	16	52	28 <sup>+0</sup> <sub>-0.052</sub>	M8×1.25	70	5	57	14	40	5.5	M6×1.0	9	Rc1/8	10	7	14	6.2	8.8	1
50	15	20	64	35 <sup>+0</sup> <sub>-0.052</sub>	M10×1.5	86	7	71	17	50	6.6	M8×1.25	11	Rc1/4(※1)	14	8	19	8.2	10.8	1
63	15	20	77	35 <sup>+0</sup> <sub>-0.052</sub>	M10×1.5	103	7	84	17	60	9	M10×1.5	14	Rc1/4(※2)	18	10.5	19	10.2	13.8	1
80	21	25	98	43 <sup>+0</sup> <sub>-0.052</sub>	M16×2.0	132	6	104	22	77	11	M12×1.75	17.5	Rc3/8(※3)	22	13.5	26	12.2	17.3	2
100	27	30	117	—	M20×2.5	156	6.5	123.5	27	94	11	M12×1.75	17.5	Rc3/8(※3)	22	13.5	26	12.2	17.3	2

※1: Without magnet with stroke=5mm, P=Rc1/8 · Q=12 · F=8

※2: Without magnet with stroke=5mm, P=Rc1/8

※3: Without magnet with stroke=5mm, P=Rc1/4

# MCJQ Installation of sensor switch $\phi 12 \sim \phi 100$

## COMPACT CYLINDERS

### Dimensions

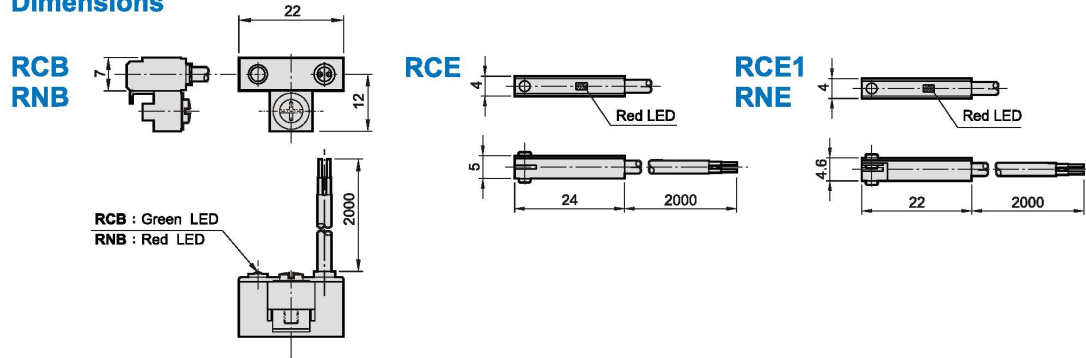

### Installation of sensor switch

$\phi 12 \sim \phi 40$

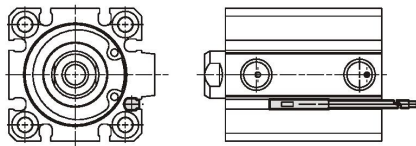

$\phi 50 \sim \phi 100$

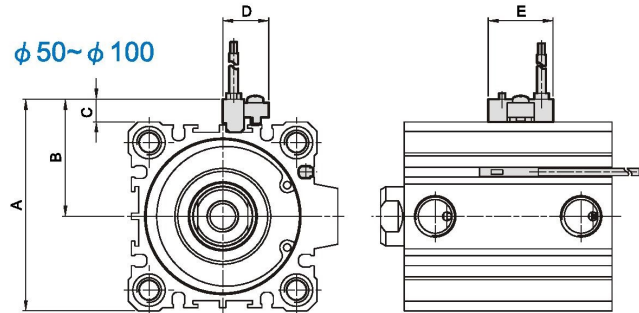

### Order example

RCE1 - □

MODEL

RCB / RCE / RCE1 ( C : Reed switch)  
RNB / RNE ( N : Solid state switch)

Blank: Lead wire  
QD: Connector

Code Tube i.D.	A	B	C	D	E
50	72	40	8	16	22
63	85	46.5	8	16	22
80	106	57	8	16	22
100	125	66.5	8	16	22

### Description

- ▽ RCB switch
- ▽ RCE,RCE1 switch

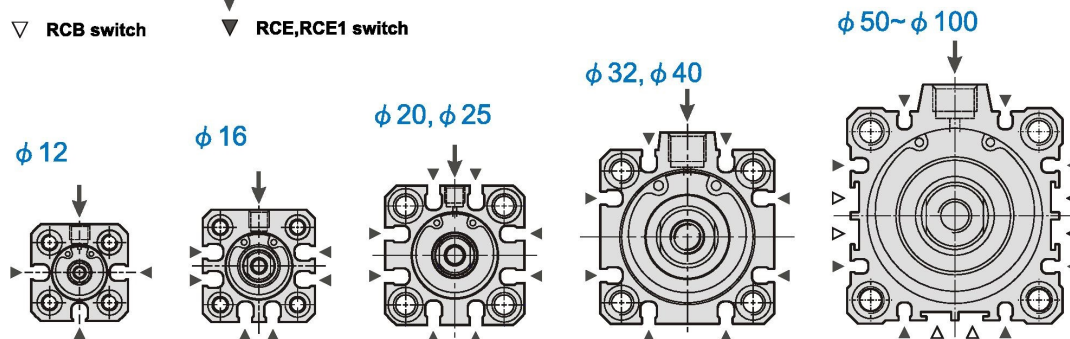

# MCJQ Mounting accessories / Double acting $\phi 12 \sim \phi 25$

## COMPACT CYLINDERS

### LB

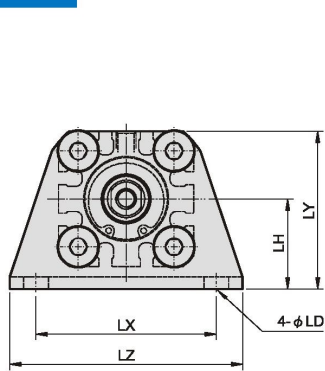

Female thread

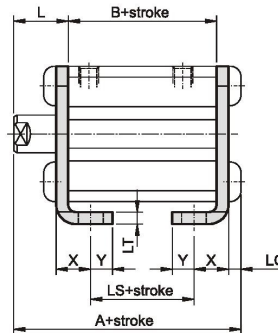

Male thread

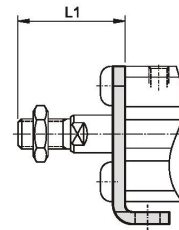

Code Tube I.D.	Standard stroke							Long stroke							L	L1	LD	LG	LH	LT	LX	LY	LZ	X	Y
	Stroke range	Without magnet			Magnet			Stroke range	A	B	LS	A	B	LS											
		A	B	LS	A	B	LS																		
12	5~30	35.3	17	5	40.3	22	10	35~100	50.3	32	20	13.5	24	4.5	2.8	17	2	34	29.5	44	8	4.5			
16	5~30	35.3	17	5	40.3	22	10	35~100	50.3	32	20	13.5	25.5	4.5	2.8	19	2	38	33.5	48	8	5			
20	5~50	41.2	19.5	7.5	51.2	29.5	17.5	75~200	62.7	41	29	14.5	28.5	6.6	4	24	3.2	48	42	62	9.2	5.8			
25	5~50	44.7	22.5	7.5	54.7	32.5	17.5	75~300	66.2	44	29	15	32.5	6.6	4	26	3.2	52	46	66	10.7	5.8			

### FAC

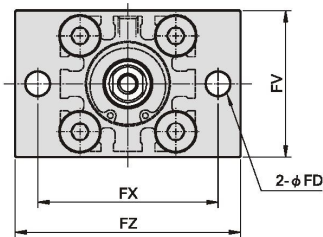

Female thread

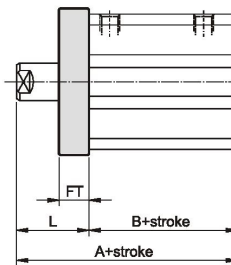

Male thread

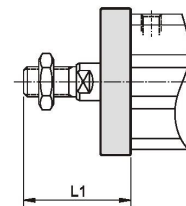

Code Tube I.D.	Standard stroke				Long stroke							L	L1		
	Stroke range	Without magnet		Magnet		Stroke range	A	B	FD	FT	FV			FX	FZ
		A	B	A	B										
12	5~30	30.5	17	35.5	22	35~100	45.5	32	4.5	5.5	25	45	55	13.5	24
16	5~30	30.5	17	35.5	22	35~100	45.5	32	4.5	5.5	30	45	55	13.5	25.5
20	5~50	34	19.5	44	29.5	75~200	55.5	41	6.6	8	39	48	60	14.5	28.5
25	5~50	37.5	22.5	47.5	32.5	75~300	59	44	6.6	8	42	52	64	15	32.5

# MCJQ Mounting accessories / Double acting $\phi 12 \sim \phi 25$

## COMPACT CYLINDERS

### FBC

Male thread

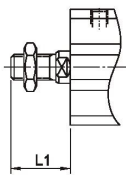

Female thread

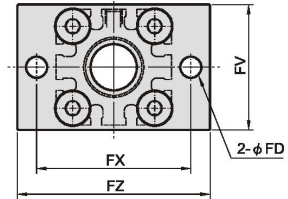
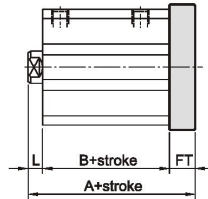

Code Tube I.D.	Stroke range	Standard stroke								Long stroke					FD	FT	FV	FX	FZ
		Without magnet				Magnet				Stroke range	A	B	L	L1					
		A	B	L	L1	A	B	L	L1										
12	5~30	26	17	3.5	14	31	22	3.5	14	35~100	51	32	13.5	24	4.5	5.5	25	45	55
16	5~30	26	17	3.5	15.5	31	22	3.5	15.5	35~100	51	32	13.5	25.5	4.5	5.5	30	45	55
20	5~50	32	19.5	4.5	18.5	42	29.5	4.5	18.5	75~200	63.5	41	14.5	28.5	6.6	8	39	48	60
25	5~50	35.5	22.5	5	22.5	45.5	32.5	5	22.5	75~300	67	44	15	32.5	6.6	8	42	52	64

### CB

Male thread

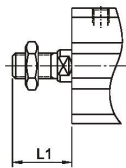

Female thread

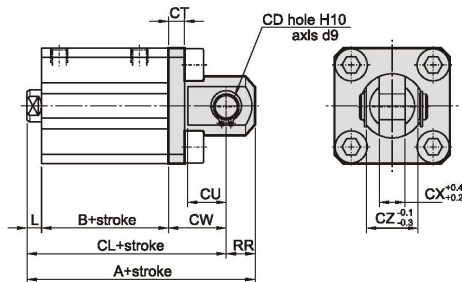

Code Tube I.D.	Stroke range	Standard stroke										Long stroke					CD	CT	CU	CW	CX	CZ	RR	
		Without magnet					Magnet					Stroke range	A	B	CL	L								L1
		A	B	CL	L	L1	A	B	CL	L	L1													
12	5~30	40.5	17	34.5	3.5	14	45.5	22	39.5	3.5	14	35~100	65.5	32	59.5	13.5	24	5	4	7	14	5	10	6
16	5~30	41.5	17	35.5	3.5	15.5	46.5	22	40.5	3.5	15.5	35~100	66.5	32	60.5	13.5	25.5	5	4	10	15	6.5	12	6
20	5~50	51	19.5	42	4.5	18.5	61	29.5	52	4.5	18.5	75~200	82.5	41	73.5	14.5	28.5	8	5	12	18	8	16	9
25	5~50	57.5	22.5	47.5	5	22.5	67.5	32.5	57.5	5	22.5	75~300	89	44	79	15	32.5	10	5	14	20	10	20	10

# MCJQ Mounting accessories / Double acting $\phi 32\sim\phi 100$

## COMPACT CYLINDERS

### LB

#### Standard stroke

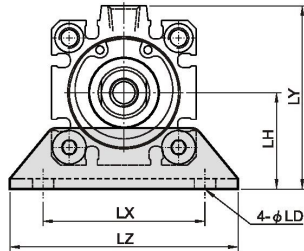

#### Female thread

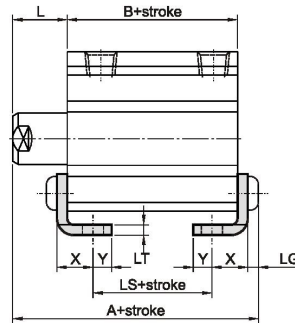

#### Male thread

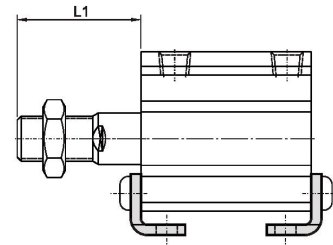

#### Long stroke

#### Female thread

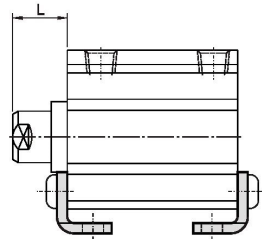

#### Male thread

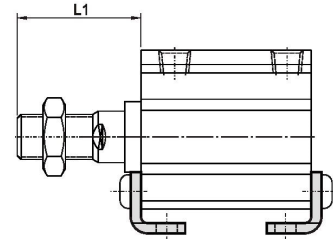

Code Tube I.D.	Standard stroke						Long stroke				L	L1	LD	LG	LH	LT	LX	LY	LZ	X	Y	
	Stroke range	Without magnet			Magnet			Stroke range	A	B												LS
		A	B	LS	A	B	LS															
32	5~50	47.2	23	7	57.2	33	17	125~300	69.7	45.5	29.5	17	38.5	6.6	4	30	3.2	57	57	71	11.2	5.8
	75, 100	57.2	33	17																		
40	5~50	53.7	29.5	13.5	63.7	39.5	23.5	125~300	79.2	55	39	17	38.5	6.6	4	33	3.2	64	64	78	11.2	7
	75, 100	63.7	39.5	23.5																		
50	5~50	56.7	30.5	7.5	66.7	40.5	17.5	125~300	81.7	55.5	32.5	18	43.5	9	5	39	3.2	79	78	95	14.7	8
	75, 100	66.7	40.5	17.5																		
63	5~50	62.2	36	10	72.2	46	20	125~300	83.2	57	31	18	43.5	11	5	46	3.2	95	91.5	113	16.2	9
	75, 100	72.2	46	20																		
80	5~50	75	43.5	13.5	85	53.5	23.5	125~300	97.5	66	36	20	53.5	13	7	59	4.5	118	114	140	19.5	11
	75, 100	85	53.5	23.5																		
100	5~50	88	53	19	98	63	29	125~300	—	—	—	22	53.5	13	7	71	6	137	136	162	23	12.5
	75, 100	98	63	29																		

# MCJQ Mounting accessories / Double acting $\phi 32\sim\phi 100$

## COMPACT CYLINDERS

### FAC

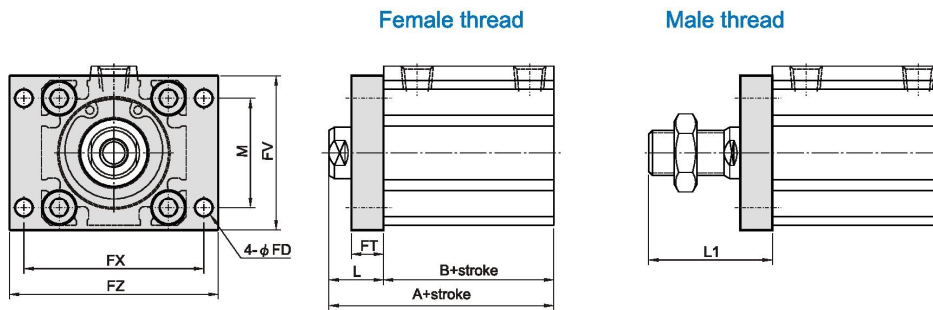

Code Tube I.D.	Standard stroke					Long stroke		FD	FT	FV	FX	FZ	L	L1	M	
	Stroke range	Without magnet		Magnet		Stroke range	A									B
		A	B	A	B											
32	5~50	40	23	50	33	125~300	62.5	45.5	5.5	8	48	56	65	17	38.5	34
	75, 100	50	33													
40	5~50	46.5	29.5	56.5	39.5	125~300	72	55	5.5	8	54	62	72	17	38.5	40
	75, 100	56.5	39.5													
50	5~50	48.5	30.5	58.5	40.5	125~300	73.5	55.5	6.6	9	67	76	89	18	43.5	50
	75, 100	58.5	40.5													
63	5~50	54	36	64	46	125~300	75	57	9	9	80	92	108	18	43.5	60
	75, 100	64	46													
80	5~50	63.5	43.5	73.5	53.5	125~300	86	66	11	11	99	116	134	20	53.5	77
	75, 100	73.5	53.5													
100	5~50	75	53	85	63	125~300	—	—	11	11	117	136	154	22	53.5	94
	75, 100	85	63													

# MCJQ Mounting accessories / Double acting $\phi 32\sim\phi 100$

## COMPACT CYLINDERS

### FBC

#### Standard stroke

Male thread

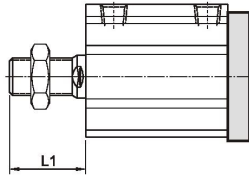

Female thread

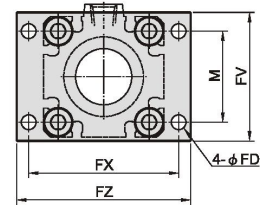
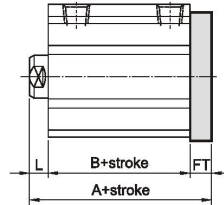

#### Long stroke

Male thread

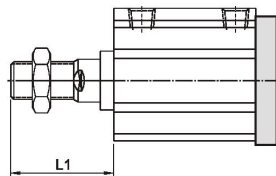

Female thread

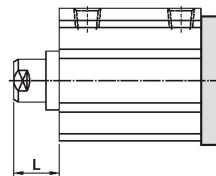

Code	Standard stroke								Long stroke									
	Stroke range	Without magnet		Magnet		L	L1	Stroke range	A	B	L	L1	FD	FT	FV	FX	FZ	M
		A	B	A	B													
32	5~50	38	23	48	33	7	28.5	125~300	70.5	45.5	17	38.5	5.5	8	48	56	65	34
	75, 100	48	33															
40	5~50	44.5	29.5	54.5	39.5	7	28.5	125~300	80	55	17	38.5	5.5	8	54	62	72	40
	75, 100	54.5	39.5															
50	5~50	47.5	30.5	57.5	40.5	8	33.5	125~300	82.5	55.5	18	43.5	6.6	9	67	76	89	50
	75, 100	57.5	40.5															
63	5~50	53	36	63	46	8	33.5	125~300	84	57	18	43.5	9	9	80	92	108	60
	75, 100	63	46															
80	5~50	64.5	43.5	74.5	53.5	10	43.5	125~300	97	66	20	53.5	11	11	99	116	134	77
	75, 100	74.5	53.5															
100	5~50	76	53	86	63	12	43.5	125~300	—	—	—	—	11	11	117	136	154	94
	75, 100	86	63															

# MCJQ Mounting accessories / Double acting $\phi 32 \sim \phi 100$

## COMPACT CYLINDERS

### CB

#### Standard stroke Male thread

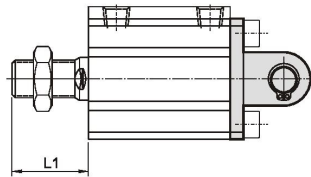

#### Female thread

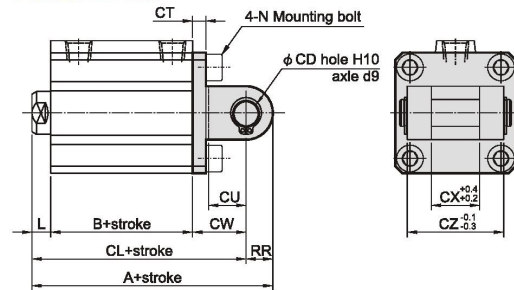

#### Long stroke

##### Male thread

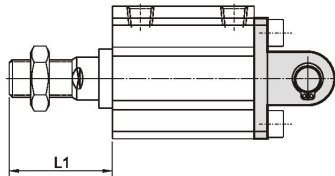

##### Female thread

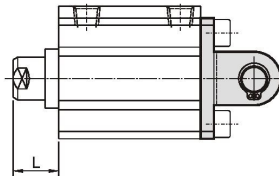

Code	Standard stroke										Long stroke					CD	CT	CU	CW	CX	CZ	N	RR
	Stroke range	Without magnet			Magnet			L	L1	Stroke range	A	B	CL	L	L1								
		A	B	CL	A	B	CL																
32	5~50	60	23	50	70	33	60	7	28.5	125~300	92.5	45.5	82.5	17	38.5	10	5	14	20	18	36	M6×1.0	10
	75, 100	70	33	60	78.5	39.5	68.5	7	28.5	125~300	104	55	94	17	38.5	10	6	14	22	18	36	M6×1.0	10
40	5~50	68.5	29.5	58.5	78.5	39.5	68.5	7	28.5	125~300	104	55	94	17	38.5	10	6	14	22	18	36	M6×1.0	10
	75, 100	78.5	39.5	68.5	78.5	39.5	68.5	7	28.5	125~300	104	55	94	17	38.5	10	6	14	22	18	36	M6×1.0	10
50	5~50	80.5	30.5	66.5	90.5	40.5	76.5	8	33.5	125~300	115.5	55.5	101.5	18	43.5	14	7	20	28	22	44	M8×1.25	14
	75, 100	90.5	40.5	76.5	90.5	40.5	76.5	8	33.5	125~300	115.5	55.5	101.5	18	43.5	14	7	20	28	22	44	M8×1.25	14
63	5~50	88	36	74	98	46	84	8	33.5	125~300	119	57	105	18	43.5	14	8	20	30	22	44	M10×1.5	14
	75, 100	98	46	84	98	46	84	8	33.5	125~300	119	57	105	18	43.5	14	8	20	30	22	44	M10×1.5	14
80	5~50	109.5	43.5	91.5	119.5	53.5	101.5	10	43.5	125~300	142	66	124	20	53.5	18	10	27	38	28	56	M12×1.75	18
	75, 100	119.5	53.5	101.5	119.5	53.5	101.5	10	43.5	125~300	142	66	124	20	53.5	18	10	27	38	28	56	M12×1.75	18
100	5~50	132	53	110	142	63	120	12	43.5	125~300	—	—	—	—	—	22	13	31	45	32	64	M12×1.75	22
	75, 100	142	63	120	142	63	120	12	43.5	125~300	—	—	—	—	—	22	13	31	45	32	64	M12×1.75	22

# MCJQ Accessories $\phi 12 \sim \phi 100$

## COMPACT CYLINDERS

### F Rear flange

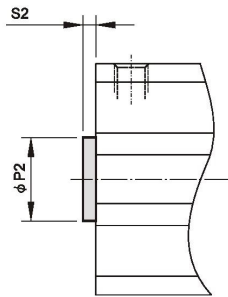

Code Tube I.D.	P2 <sup>h9</sup>	S2
12	6	1.5
16	10	1.5
20	13	2
25	15	2
32	21	2
40	28	2
50	35	2
63	35	2
80	43	2
100	59	2

### RF

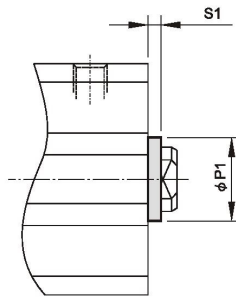

Code Tube I.D.	P1 <sup>h9</sup>	S1
12	15	1.5
16	20	1.5
20	13	2
25	15	2
32	21	2
40	28	2
50	35	2
63	35	2
80	43	2
100	59	2

### Rod front nut

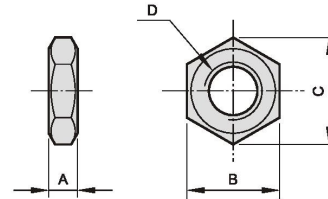

Code Tube I.D.	A	B	C	D
12	4	8	9.2	M5×0.8
16	5	10	11.5	M6×1.0
20	5	13	15	M8×1.25
25	6	17	19.6	M10×1.25
32,40	8	22	25.4	M14×1.5
50,63	11	27	31.4	M18×1.5
80	13	32	37	M22×1.5
100	16	41	47.3	M26×1.5

### Pin for CB

#### Order example

PIN—MCJQ—20—CB—P

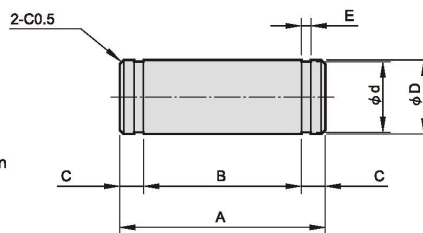
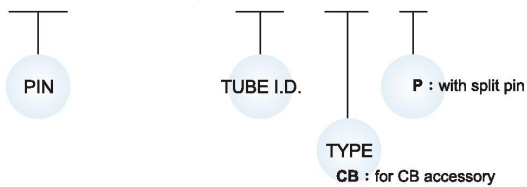

Code Tube I.D.	A	B	C	$\phi D^{d8}$	$\phi d$	E	Snap ring
12	14.6	10.2	2.2	5 <sup>-0.03</sup> <sub>-0.06</sub>	4.8 <sup>0</sup> <sub>-0.04</sub>	0.7 <sup>+0.10</sup> <sub>0</sub>	STW-5
16	16.6	12.2	2.2	5 <sup>-0.03</sup> <sub>-0.06</sub>	4.8 <sup>0</sup> <sub>-0.04</sub>	0.7 <sup>+0.10</sup> <sub>0</sub>	STW-5
20	21	16.2	2.4	8 <sup>-0.04</sup> <sub>-0.08</sub>	7.6 <sup>0</sup> <sub>-0.08</sub>	0.9 <sup>+0.10</sup> <sub>0</sub>	STW-8
25	25.6	20.2	2.7	10 <sup>-0.04</sup> <sub>-0.08</sub>	9.6 <sup>0</sup> <sub>-0.06</sub>	1.15 <sup>+0.14</sup> <sub>0</sub>	STW-10
32,40	41.6	36.2	2.7	10 <sup>-0.04</sup> <sub>-0.08</sub>	9.6 <sup>0</sup> <sub>-0.09</sub>	1.15 <sup>+0.14</sup> <sub>0</sub>	STW-10
50,63	50.6	44.2	3.2	14 <sup>-0.05</sup> <sub>-0.10</sub>	13.4 <sup>0</sup> <sub>-0.11</sub>	1.15 <sup>+0.14</sup> <sub>0</sub>	STW-14
80	64	56.2	3.9	18 <sup>-0.05</sup> <sub>-0.10</sub>	17.0 <sup>0</sup> <sub>-0.11</sub>	1.35 <sup>+0.14</sup> <sub>0</sub>	STW-18
100	72	64.2	3.9	22 <sup>-0.07</sup> <sub>-0.12</sub>	21.0 <sup>0</sup> <sub>-0.21</sub>	1.35 <sup>+0.14</sup> <sub>0</sub>	STW-22